

Sunrise International Company

Building Industry & Creating Jobs
Manufacturing Construction Materials in Benue State



We sell molds and equipment to manufacture cultured marble bathroom and kitchen building materials.

Cultured marble is also known as:

- Engineered Stone
- Composite Materials
- Solid Surface

You can make a total of 16 different formulas and techniques using our system.

When we sell a factory...

1. We come to you and assemble the factory.
2. We give you all the technical know-how to manufacture.
3. We train you and your newly hired employees how to use a precise blend of raw materials to make the most exquisite bath and kitchen products in the world.
4. We will train your staff how to sell the products.

Your local home builders will never have to import again.

There are over 2,500 factories in towns and cities across America manufacturing these exquisite products for their local construction industry.

There are many magnificent reasons to manufacture locally.

1. Create wealth.
2. Create Jobs
3. Keep profits in country.
4. Stop local currency flight.
5. Decrease cost of goods by avoiding freight cost and import duties.
6. Shorten the supply chain that covid destroyed.
7. Quicker Time-To-Market
8. Eliminate the carbon footprint for these types of products.
9. Ability to produce custom products; any color, size or shape.
10. It will spur economic development in all areas of the local economy.
11. Manufacturing and buying locally creates a sense of patriotism.
12. There is no language barrier that often creates costly problems.
13. Manufacturing drives innovation.

In many developing countries it's not uncommon to see a vast majority of the construction materials imported, including sinks, tubs and showers.

These are the countries who can least afford to lose manufacturing jobs to foreign countries.

These are some news headlines we've seen recently.

1. The Philippines is hugely dependent on imported construction materials
2. 80% of Building Materials Are Imported in Ghana
3. 90% Nigerian Construction Materials Imported
4. Cambodia imported \$1.83 billion worth of building materials.

How hard can it be to make a sink like this?
Not hard at all, actually.



More jobs are created by manufacturing than any other sector.

More wealth is created by manufacturing than any other sector.

Unemployment rate in Nigeria in 2020, by state

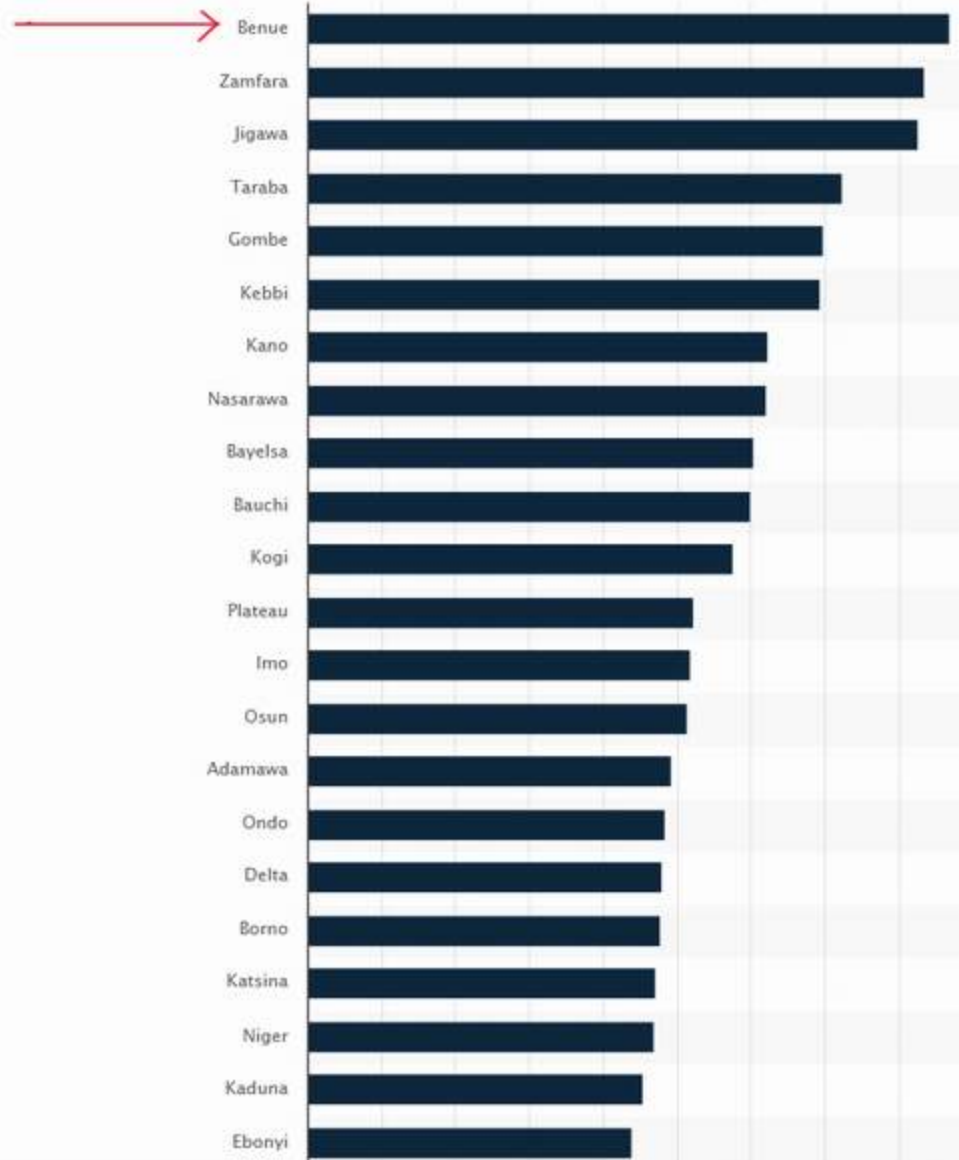

America & Europe (and now China) created their wealth manufacturing.

Africa exports raw materials & imports them as finished goods.

Poor countries that don't manufacture and spend all their money on imports will always remain poor.

The difference between Vietnam's GDP and Nigeria's GDP is because of

'Manufacturing'.

Interesting article:

"Nigeria Drags as Vietnam Lifts 45m Citizens Out of Poverty."

<https://bit.ly/3xkNUI2>

Nigeria

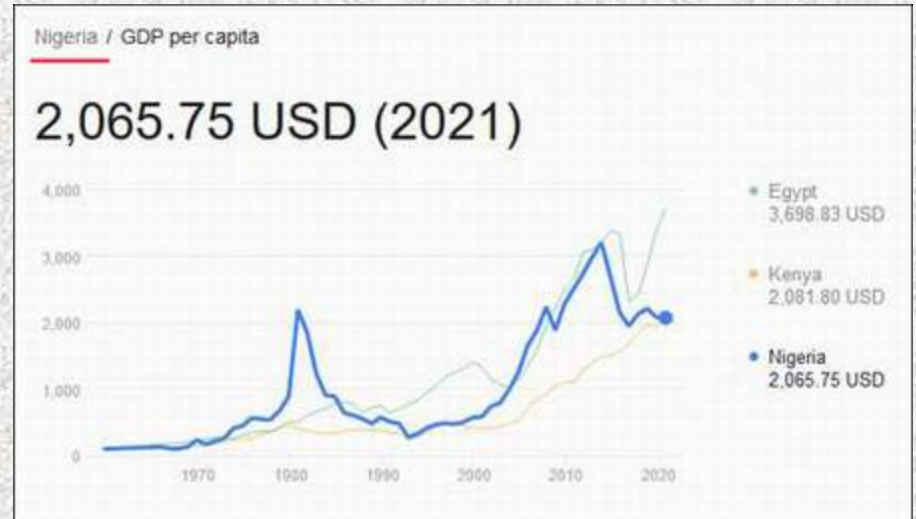

Vietnam

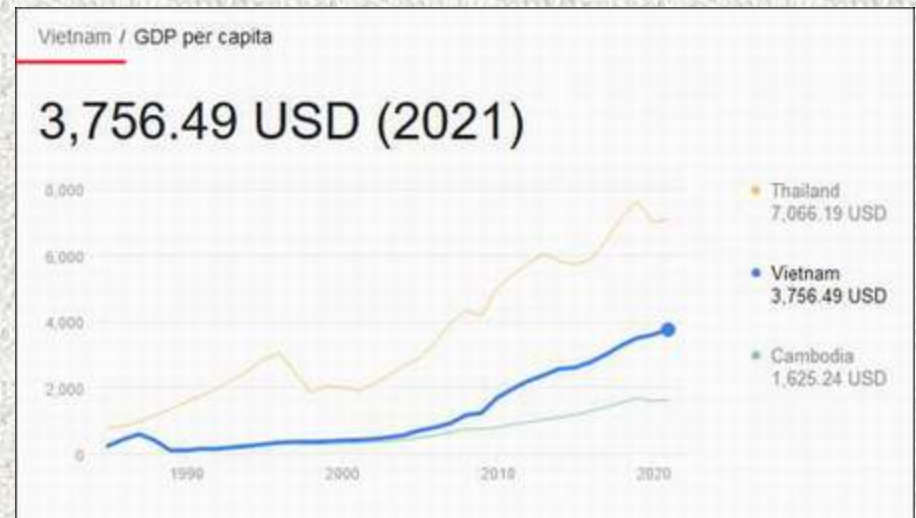

The Top 18 Facts You Need to Know About Manufacturing.

Don't believe me. This is from the (American) National Association of Manufacturers
<https://www.nam.org/facts-about-manufacturing/>

The Top 18 Facts You Need to Know About Manufacturing

1. Manufacturers contributed \$2.81 trillion at the annual rate to the economy, based on Q3 2022 data
2. For every \$1.00 spent in manufacturing, there is a total impact of \$2.60 to the overall economy.
3. The majority of manufacturing firms in the United States are quite small.
4. The manufacturing sector employed 12.93 million workers in December 2022.
5. Manufacturing employees earned \$95,990 on average in 2021, including pay and benefits.
6. 91% of manufacturing employees were eligible for health insurance benefits in 2022.
7. There were 779,000 manufacturing job openings in November 2022.
8. By 2030, 4 million manufacturing jobs will likely be needed.
9. U.S.-manufactured goods exports totaled roughly \$1.4 trillion in 2021.
10. Manufactured goods exports have grown substantially over the past couple decades.
11. World trade in manufactured goods has risen in the past two decades.
12. World trade in manufactured goods has more than doubled.
13. Manufacturing in the United States would be the eighth-largest economy in the world.
14. Foreign direct investment in U.S. manufacturing reached nearly \$1.9 trillion in 2020.
15. U.S. affiliates of foreign multinational firms employed over 2.8 million manufacturing workers.
16. Manufacturers perform just more than 55% of all private-sector R&D.
17. Manufacturers consume more than 30% of the nation's energy.
18. The cost of federal regulations falls on manufacturers.

There are over 2,500 hundred cultured marble factories in the USA.

Benue State and all of Nigeria has a strong home construction industry

igbere television HOME ABOUT US ADVERTISE GUEST POSTS

Home Politics | Benue Governor Rev. Fr. Alia Flags Off Housing Project On First Day in Office (Photos)

May 29, 2023

f FACEBOOK t TWITTER @ PIN IT in LINKEDIN BUFFER NEWS POLITICS

Benue Governor Rev. Fr. Alia Flags Off Housing Project On First Day in Office (Photos)



Group applauds Benue gov on housing project

1st June 2023



**HOUSING DEVELOPMENT
ADVOCACY NETWORK**

In a statement signed by the Executive Director, HDAN, Festus Adebayo, on Thursday, the housing group applauded the initiative as it will help alleviate unemployment and create job opportunities.

“Housing remains a key to solving unemployment issues in any state and any governor that wants to tackle unemployment must be housing friendly because when people are housed, the problem is reduced,” he pointed out.

Links to Housing Unit Projects in Nigeria

Hundreds of thousands of sinks, bathtubs, showers, countertops and other bath and kitchen building materials will be needed to supply these homes. Hotels, hospitals, clinics, schools, restaurants, fast food establishments, bars, coffee shops, banks and other types of businesses that will spring up around these developments will also require these building materials. Will they be imported or manufactured locally in Nigeria, by Nigerians for Nigerians?

Minister Ahmed Dangiwa Performs Groundbreaking of 480-housing Unit Project in Abuja
December 1, 2023 - [Click here](#)

FG launches mortgage scheme for Nigerians in diaspora at 6.9% interest rate
Nov 15, 2023 - [Click here](#)

Housing deficit: FG plans to provide 80,000 houses in eight years
Nov 14, 2023 - [Click here](#)

Nigeria FG Plans Affordable Houses for Vulnerable Nigerians
Nov 14, 2023 - [Click here](#)

FG to provide 80,000 houses in 8 years
Nov 13, 2023 - [Click here](#)

FG working on road map to create social housing scheme – Permanent Secretary
Nov 13, 2023 - [Click here](#)

FG to award survey contracts for nationwide housing scheme
Nov 13, 2023 - [Click here](#)

Minister of Housing Musa Dangiwa promises to build 10,000 houses in Abuja
Nov 10, 2023 - [Click here](#)

Nigeria FG to Provide 5.5 Million Housing Units ove 10 Years - Housing Minister
Nov 8, 2023 - [Click here](#)

FG plans affordable homes for 80% low-income earners
Oct 23, 2023 - [Click here](#)

Abuja estate firm plans 10,000 housing units
Sept 12, 2022 - [Click here](#)

Nigeria FG to construct 1,000 houses in seven northern states – Shettima
Sept 9, 2023 - [Click here](#)

FG To Construct 7,000 Houses In Kaduna, Sokoto, Kebbi, Katsina, Zamfara, Niger and Benue States
Sept 8, 2023 - [Click here](#)

There are thousands of homes being built in Nigeria.

Nigeria has a 20 million housing deficit.

Home construction will be an ongoing indefinitely.

To see list go to:

<https://www.culturedmarblemolds.com/nhplist.html>

But, the dirty little secret that nobody wants to talk about is...

90% Nigerian construction materials imported – Building institute



<https://punchng.com/90-nigerian-construction-materials-imported-building-institute/>

This is embarrassingly outrageous.

These must be manufactured locally.

- We will come to set up your factory
- We will give you all technical know-how.
- We will train your new staff how to manufacture.
- We will train your staff how to market the products.

When was the last time someone dropped something like this in your lap?

- You will create jobs
- You will be able to manufacture the most exquisite bath and kitchen construction materials Nigeria has ever seen.
- You will manufacture engineered marble, onyx and granite.
- You will manufacture any color imaginable.
- You can eliminate the need to import any bathroom fixtures.

Locally manufacture bath/kitchen construction materials by Benue people for Benue people and for export.

Our molds, equipment and technology will allow you to make sinks, bathtubs showers and many other construction materials.

Cultured Marble (engineered stone) is a mixture of crushed Limestone which Nigeria has in abundance, resin & pigments.

You pour matrix over our specially designed molds, let it cure and pop it off - ready to install.

No costly curing ovens, no grinding no buffing and since it is cured chemically, it requires very little electricity.

The molds produce an exact replica of what you want to make.

A bathtub mold makes a bathtub.



A sink mold makes a sink.



A shower pan makes a shower pan, etc.



It's basically as simple as that.

We will come to set up your factory and train your staff. We'll discuss training details later.

The four most common questions we get is:

1.Can I make money?

2.Can I really Manufacture quality products in Nigeria

3.How much does it cost to set up a cultured marble factory?

4.How do I get started?

You'll find the answer to these questions and more, following.

You will have about \$5 in materials in a simple drop-in sink like this.



72" Double Bowl Vanity Top with two end splashes

Total Material
Cost: \$56.12



Bathtub/Shower Surround

Total Material Cost: \$185.00



Shower Pan

36" X 36" Shower Pan: 55 KG

Total Material Cost: -----\$52.00





Large Corner Bathtub

Large corner bathtub - 100 KG.

Total Material Cost = \$92.00

Potential Profit

We are often asked, 'how much can I make' if I set up a factory to meet the needs of a particular housing project that is going to be built in my area.

Here's a glimpse of one and in two more pages here you'll see links to other projects that we've uploaded on our website.

Raw Material Cost Worksheet - Calculator Based on Resin Costing \$2.50 Per KG

The chart below shows how I came to the total material cost of \$.84 per Kilogram for cultured marble.

	Raw Material Percentage	Total KG Raw Material Percentage	Cost Per KG	Total Raw Material Cost Per 1 KG
Resin Cost Per KG	25% Resin	0.25	\$ 2.50	\$ 0.63
Limestone Cost Per KG	75% Limestone	0.75	\$ 0.10	\$ 0.08
Total Resin + Limestone Cost Per 1 KG Matrix				\$ 0.70
Add 20% for Gel Coat, wax, tape, clay, pigment etc.				\$ 0.14
TOTAL RAW MATERIAL COST PER 1 KILOGRAM				\$ 0.84

This is a simple 2 bedroom - 1 bath home that we used in for this spreadsheet.

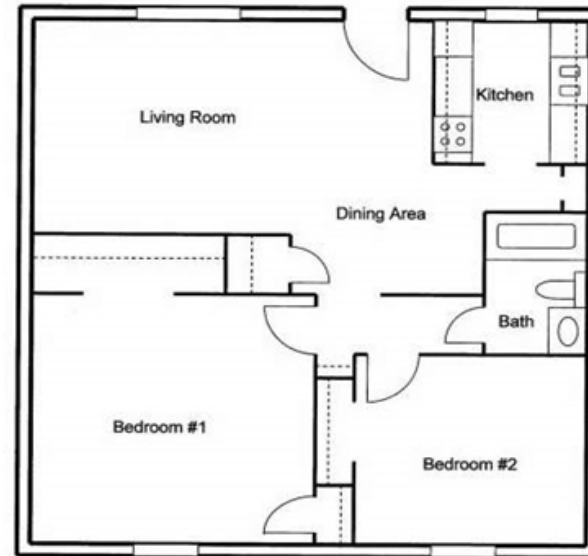

The material cost calculation is based on resin, your highest material cost, costing \$2.50 USD per kilogram. If you are doing a large project where you know your production will be high, you can buy resin in larger quantities direct from the manufacturer between \$2.25 and \$2.50 per kilogram. If you're doing small quantities and buying from a local distributor, it will cost between \$3.00 & \$3.50 per kilogram. If you're seeing this in Excel format, you can simply change the 'cost per kilogram' for your resin and filler.

Potential Profit Margin for 1,800 Single Bathroom Homes in Edo State

<https://bit.ly/2M9xkSi>

This spreadsheet shows material costs and potential profit margins to manufacture the bath and kitchen fixtures for the 1,800 housing units proposed in Edo State. We don't have construction details but we will assume they will be simple, ONE-bathroom homes as shown on the sample floor plan on the following page. If these housing units include more bathrooms, that is all the better. The spreadsheet lists the fixtures in each unit and details each item's cost, approximate selling price and potential profit, less labor and overhead cost. By doing a local market survey you can more accurately determine the selling price. Selling price, less material cost, labor and overhead will give you your true net. Job creation, utilizing local raw materials, currency not leaving the country, export potential and trickle down effect of local industry brings great value to manufacturing these cultured marble bath and kitchen building materials locally.

Product List & Description as shown in attached drawing	Quantity	Weight (KG) Each Piece	Total Kilograms	Cost Per Kilogram	Total Material Cost	Approximate Selling Price	Selling Price Less Material Cost
Master Bath							
30" (75cm) Single Bowl Vanity Top	1	48	48	\$ 0.84	\$ 40.32	\$ 150.00	\$ 109.68
End Splashes	1	2	2	\$ 0.84	\$ 1.68	\$ 15.00	\$ 13.32
31" X 60" (78cm X 152 cm) Bathtub	1	105	105	\$ 0.84	\$ 88.20	\$ 385.00	\$ 296.80
60" X 19" X 3/8" Tub Skirt	1	14	14	\$ 0.84	\$ 11.76	\$ 41.00	\$ 29.24
Soap/Shampoo Holder	1	7	7	\$ 0.84	\$ 5.88	\$ 30.00	\$ 24.12
60" X 60" (152cm x 152 cm) Flooring	1	60	60	\$ 0.84	\$ 50.40	\$ 200.00	\$ 149.60
Baseboard Moulding	1	9	9	\$ 0.84	\$ 7.56	\$ 15.00	\$ 7.44
Kitchen							
12 Ln Ft (3.6m) Counter Top (\$1.35 ln/cm)	1	105	105	\$ 0.84	\$ 88.20	\$ 486.00	\$ 397.80
8 Ln Ft (2.4m) Counter Top (\$1.35 ln/cm)	2	70	140	\$ 0.84	\$ 117.60	\$ 324.00	\$ 206.40
Double Bowl Kitchen Sink	1	24	24	\$ 0.84	\$ 20.16	\$ 165.00	\$ 144.84
Total Material Cost/Sales Cost/Profit					\$ 431.76	\$ 1,811.00	\$ 1,379.24
Total KG Material for each housing unit			514				
Based on above numbers, gross profit (less labor cost & overhead) for the 1,800 housing units would be: ----->							\$ 2,482,632.00

To estimate labor cost you can assume that an experienced labor force can produce an average of 500 kilograms per day per person. See how we calculated our material cost on the following page.

These are the links we referred to earlier that show 'potential profits' on housing projects people have sent us. These are from various countries in Africa. Unless otherwise noted, most of these are based on each housing unit having only ONE bathroom.

Potential Profit Margin Spreadsheets

1,000 Unit Single Bath Housing Units: https://www.culturedmarblemolds.com/Potential_Profit_1.pdf

2.5 Bath House or Apartment: http://www.culturedmarblemolds.com/Potential_Profit_2.pdf

4 Bath House: http://www.culturedmarblemolds.com/Potential_Profit_4.pdf

5,000 Units - 2 Bath Immigration Personnel Abuja https://www.culturedmarblemolds.com/Potential_Profit_3.pdf

1900 Unit Housing Project - Kenya: https://www.culturedmarblemolds.com/Potential_Profit_5.pdf

2500 Units Zambia: https://www.culturedmarblemolds.com/Potential_Profit_6.pdf

10,000 Units Zimbabwe: https://www.culturedmarblemolds.com/Potential_Profit_7.pdf

5,000 Unit Single Bath Housing Project: https://www.culturedmarblemolds.com/Potential_Profit_8.pdf

Potential customers for a cultured marble factory is vast
Some of your market will include:

Architects,
Homebuilders,
Apartment Builders
General Contractors
Home Improvement Contractors
Hospitals
Clinics
Restaurants
Coffee Shops / Bars
Bathroom Remodelers
Fast Food Establishments
Plumbing Contractors
Food Kiosk Vendors/Suppliers
Plumbing Supply Stores
Flooring Contractors
Restaurant Supply Wholesalers
Ceramic & Marble Tile Distributors
Hotel/Motels
Banks
Real Estate Agents
Government Offices
Stair Builders
Nursing Homes
Furniture Manufacturers

Schools
Student Housing/Dormitories
Interior Designers
Fitness Centers
General Carpenters
Cabinet Makers
Motor Home Manufacturers
Mobile Home Manufacturers
Glass Companies (Mirrors etc.)
Motor Home & Boat Customizing Shops
Shower Door Suppliers & Installers
Bathroom Specialty Stores
Window Treatment Centers
Partitions
Property Management Companies
Pet Supply Stores
Lumber Yards
Trophy Makers
Bakeries
Fireplace Shops
Donut Shops
Shelving Suppliers
Fitness Centers
Handicap Remodel Contractors

There are many areas outside the bathroom and kitchen where cultured marble is a perfect fit. Look around your home and office and take note of all the areas that need a finished surface, e.g. window sills, bay windows, stairway railings, steps, flooring, laundry tables, built-in desks and more.

These and other areas need some sort of finished surface so it may as well be yours.

**Cultured Marble Installations
and the Molds Needed
To Produce Them**

Regardless of the size of investment, our goal is to supply you with as a diverse assortment of molds to produce as many different products as possible. For example, here we are using divider bars to make varying lengths of vanity tops.

The sinks on the following pages are all made using this same mold.



So, whether you're making a vanity top with one bowl...



Two bowls..



or more bowls, they can all be made on the same counter top mold





Only 3 molds are needed for this elegant bathtub installation.

- (1) Bathtub Mold
- (2) Wall Panel Mold
- (3) Trim Mold



This is a close up of the corner shelf in corner bathtub installation

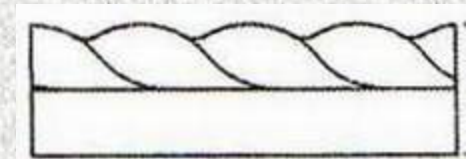
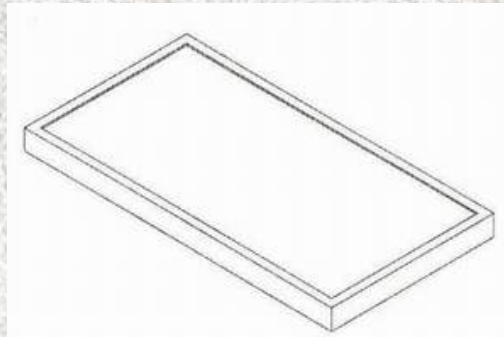
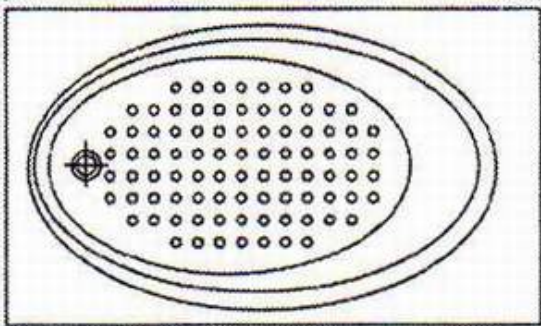



Only four molds were used in this complete bathroom installation.

Bathtub Mold

- (1) All Purpose Mold
- (2) Drop In Bowl Mold
- (3) Wall panel Mold
- (4) Shower Pan Mold

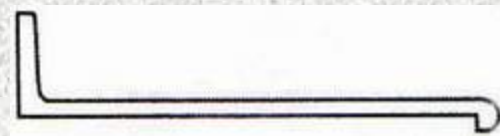
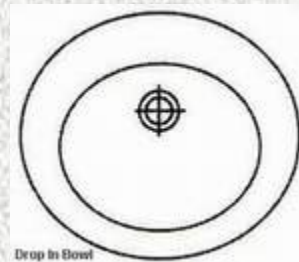
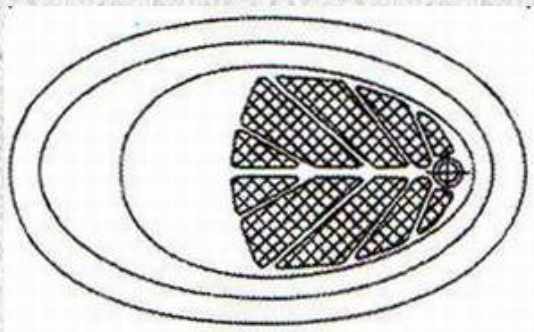
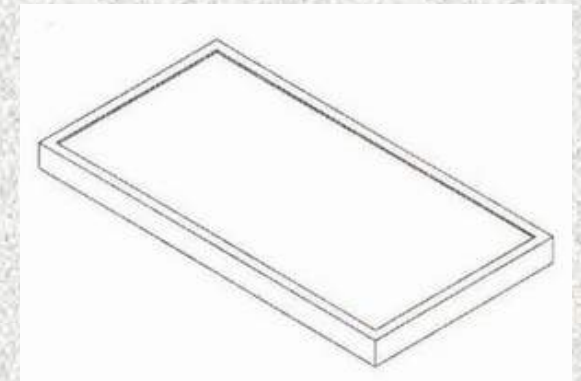
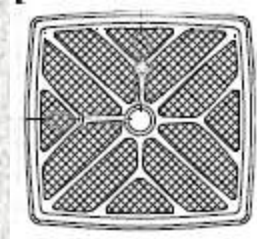

Think Colors!

You can make any color on earth!

If your customer wants a hot pink bathtub, you can make it!



If your customer wants sizzling red sparkling granite, you can make it.



If your customer wants sparkling Nigerian green metal flake, you can make it.



If your customer wants a blue bathtub with some crazy waves in it, you can make it!



Any size – any color



Color Choice is a huge reason many people will be knocking on your door. People want choices that imported goods do not offer.

We will show you how to make Granite colors as well.

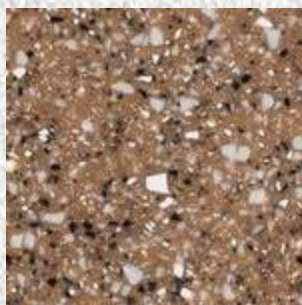

You can make majestic Grecian columns in any color.



**Enter the lucrative
"Custom Made"
Market**

The 'Custom' market is very lucrative.

Here we are making a large seamless "L" shaped counter top with built-in bowls?

Make a template, lay it out on the wall panel mold, set your divider bars and floating bowls and pour your matrix over it. Simple as that.

Marble/Onyx/Granite – any color your customer desires.

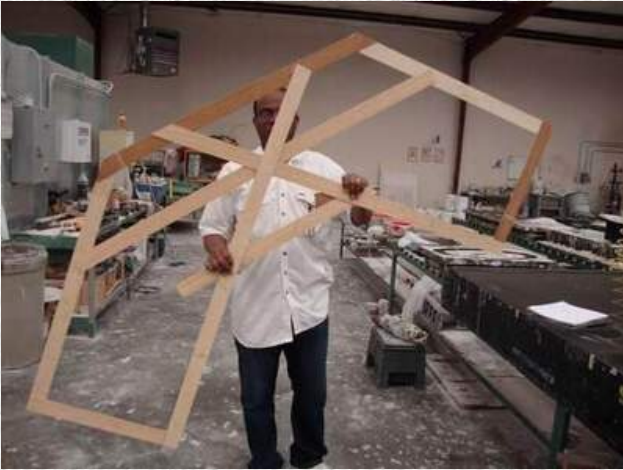

Here's an elegant custom vanity top with a make-up table that your customer would never get in an imported box.



Here's a very unique installation a factory put in their showroom just to show what they can do. They included a custom shower pan, inside corner trim, outside corner trim, baseboard trim, a double wide recessed soap dish, a corner shelf shampoo bottle holder and a shower seat, all inside a custom size shower pan.



We have many shower pan molds sizes to choose from but sometimes there's a need to make something, 'custom' size.

Below is a Universal Shower Pan mold being set up with divider bars to make a 'custom' size shower pan. You can make the whole bathroom floor one big seamless shower pan if you wanted to.

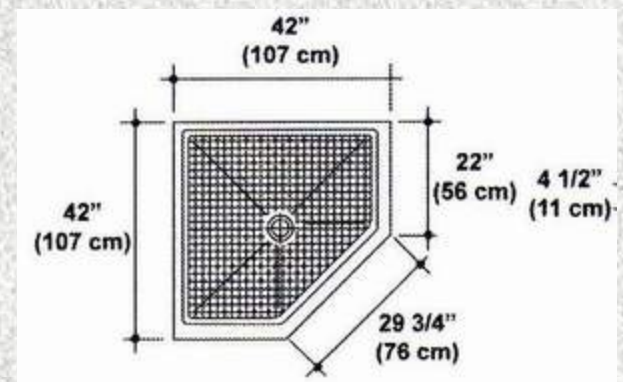
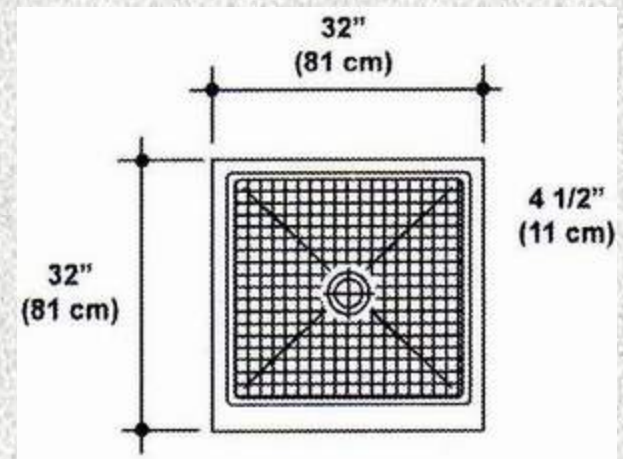
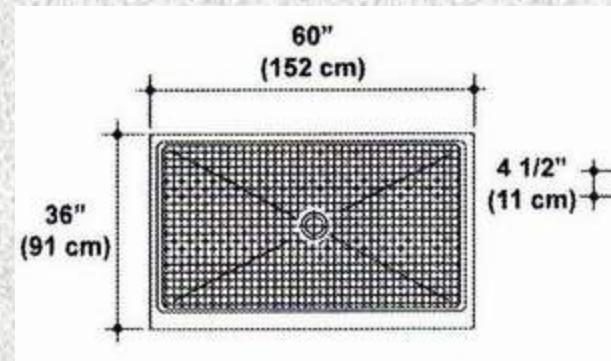
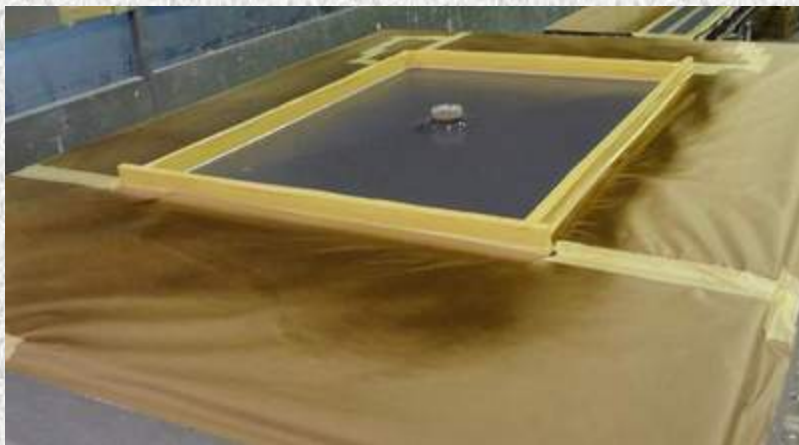

There are many scenarios on a construction site where a 'custom' pan, made-to-size, would be ideal. Notice how this one has an angle on the right size.



Another elegant, unique and custom hotel vanity installation.



It's all about custom, right?
Size, shape, colors and flower inlays like this



Textured Finishes

Textured Surfaces

Seamless cultured marble flooring or wall paneling has no grout lines so there is no place for dirt to hide and is easy to clean.



With textured paneling you get the tile appearance but with no grout lines !



Your customer will love you when you show them how they can have their cake (tile appearance) and eat it too (No grout)



Look outside the bathroom

You can make any size or shape table top by simply making a template. Read our article about making/marketing table tops on our Blog.

<https://culturedmarblemolds.blogspot.com/2015/02/cultured-marble-granite-table-tops.html>



Every restaurant, bar, coffee shop and home needs table tops. They're easy to manufacture and create fast cash flow. Read more about table tops on our blog at: <http://culturedmarblemolds.blogspot.com/>



You can make them a table top to fit, any color, and simply drop it over the top of their existing one.



Transparent Cultured Onyx table tops with circular table base using 'Flexible' onyx. The two pictures are of the same table.

The picture on the left shows it being backlit, making it a nice night-light.



It's been documented that there are there are **3,389** coffee shops in NYC. I'm sure many of them need to be replaced.

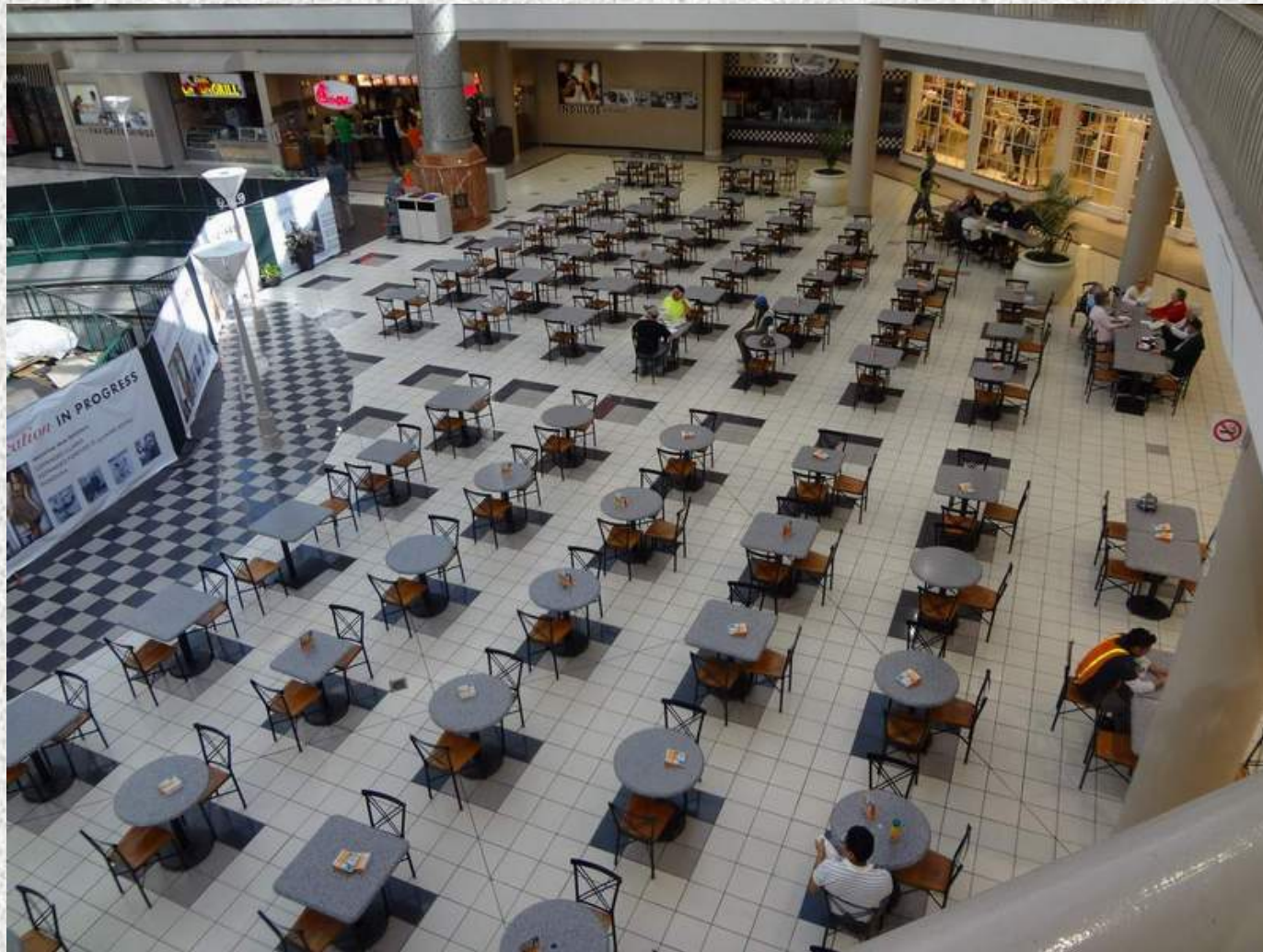

Here we're making a large conference table.



Table Top Ads

Everybody sells Ads; Google, Facebook, Twitter, etc. You make money selling the table tops and your customer makes money selling ads that will go into the cutout you made on the table top. Or, you can do both.



Nothing dresses up windows better than a marble window sill.
The design comes off the mold like this and can be install throughout the house.



Hotels are huge users of cultured marble. There is nothing more sanitary and easier to clean than a cultured marble sink, bathtub, shower pan and grout-free shower surrounds. Every guest room is like a single bath home so a 200 Unit hotel is like supplying 200 single bath homes.



Bathroom Sinks



Grout-Free showers



Most hotels have a breakfast buffet area.



Another hotel breakfast bar



Hotel In-Room Coffee Area



Don't forget the toilet paper holder.



McDonalds, Burger King, Wendy's and all other fast food places used our products because They are seamless and no place for dirt and germs to hide.

Front Counter



Condiment table



Trash Can Receptor



Dining tables



Bar, restaurant and fast food counters



Most all fast food establishment's front counters are a seamless because they can't risk being the cause of any foodborne illness.



Look around your home and office for other places a nice finished surface is needed.













Accessories for the Bath
Return great profits

Profit margins per pound or kilogram are often bigger on small accessories items than on bigger products.



You can increase your margins even more by doing some very 'custom' things.



There are many styles and sizes of accessory molds to choose from. Here is a Double Wide Recessed Soap & Shampoo Combo



A single wide Recessed
Soap/Shampoo Combo



Maybe a simple Corner Shelf suits your customer better.



Shelf, often used in the Shower.



Decorative Trim molding



Shower seats



Mirror Frames



**Manufacturing
In five
Simple Steps**

1. Set Up Mold



2. Spray Gel Coat On Mold



3. Prepare Raw Materials & Mix Matrix. Resin, Limestone, Hardener, Colors



4. Pour the matrix over the mold and let it harden



De-mold



Bathtubs 

Bathtubs are very simple to make and bring substantial profits.

They are fast and easy to make.

No set up is required.

There are a variety of sizes available.

There is no type of bathtub on the market that is stronger, more elegant, more luxurious and more durable than a cultured marble, onyx or granite tub.

You can add a Jacuzzi system to any size bathtub you make.

You can make simple little bathtubs...



Or something a little larger and more elegant...



By drilling 6 holes and adding some simple PVC plumbing, you can almost double the value of this bathtub by installing a Jacuzzi system.



This is a standard bathtub but notice the added touch (and value) by adding a bullnose tub deck and a marble decorative trim molding at the base of the bathtub.



Edge Styles

We will train you how to make everything from simple straight edge styles on your counter tops like this do more elegant custom edges that will bring you even more profit.

This sink has a simple straight edge.



Bullnose Edge



Ogee Edges are very popular



Double Ogee



Double Drop Ogee Edge Style



Chamfer Edge Style



Dripless Edge Style



A 10 CM drop front edge



Cultured Marble Shower Pans

Cultured Marble vs Ceramic Tile Showers

A tile shower floor is one of the most unhygienic places in a house. If you know anyone who suffers from allergies or has sinus or respiratory problems, install a Seamless & grout-free cultured marble shower pan.

The grout in tile showers absorbs moisture like a sponge and may never dry out, causing toxic mold and mildew to grow. If left unchecked, respiratory problems can lead to serious health problems.



A cultured marble shower pan is one solid piece of rock formed over a shower pan mold. It has absolutely no seams or grout lines so it's easy to keep clean and 100% sanitary. A cultured marble shower surround consists of 3 large wall panels and again, there are no seams or grout lines so there is no place for mold to grow, soap scum to accumulate or dirt to hide. Notice the built-in shower seat.



Cultured marble shower pans are the strongest on the market and are virtually indestructible. Cultured marble is four times the tensile strength of ceramic or natural marble and cultured marble won't break or crack like fiberglass or acrylic shower pans do.



Here is a cultured marble shower surround over a bathtub. A nice clean installation. Notice the trim that is installed at the top of the shower. → It goes to show that “if you show it you’ll sell it”

A jetted whirlpool system like in the bathtub below can be added to any bathtub you manufacture.



Acrylic tubs and shower pans are notorious for cracking. I know a factory that got a contract to replace all the cheap acrylic shower pans in a hotel after the pans started cracking. It a very costly mistake.

Many marble factories will put an acrylic bathtub and shower pan in their showroom and have their prospective customers step in them. They'll spring up and down like a diving board. They'll then have them step into one of their solid-as-a-rock marble tubs and pans. It's a sale every time.



Your shower pan will never crack or break.



Manufacturing Process And Equipment

Regardless of the size of the factory, the manufacturing process and sequence is the same and will follow this path through your factory.

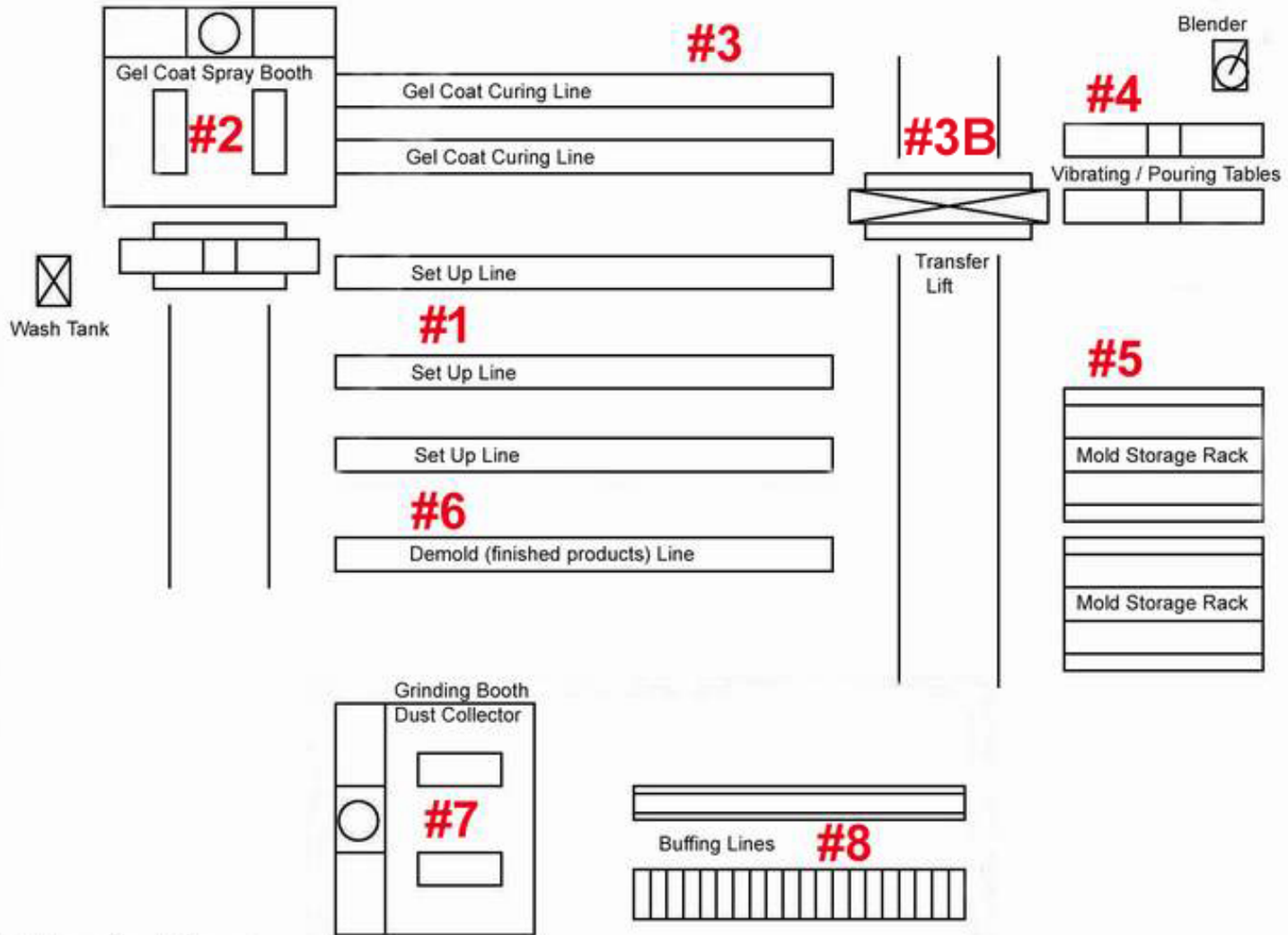

1. Set Up Lines



2. Spray Booth and Gel Coat Spray Cart



3. Gel Coat Curing Line



4. Matrix Blenders



4. Vibrating Tables



3B. The Scissor Lift moves the molds in and out of the Mold Storage Racks



5. Mold Storage Racks



6. De-mold & Transfer Line



7. Dust Collector / Grinding Booth



8. Vanity Top Buffing Line



How do I get started ?

Decide your budget and choose the size of package that best suits your budget.

\$ 500K - Cultured Marble Factory.xlsx

	A	B	C	D	E
1				1-Jan-24	
2					2
3	\$500,000 Cultured Marble Factory				
4	Name				
5	Address				
6	City, State, Country				
7	Tel:		E-mail:		
8					
9	Mold Description				
10					

\$ 800K - Cultured Marble Factory.xlsx

	A	B	C	D	E
1				1-Jan-24	
2					2
3	\$800,000 Cultured Marble Factory				
4	Name				
5	Address				
6	City, State, Country				
7	Tel:		E-mail:		
8					
9	Mold Description				
10					

\$ One Million - Cultured Marble Factory.xlsx

	A	B	C	D	E
1				1-Jan-24	
2					
3	\$1,000,000 Cultured Marble Factory				
4	Name				
5	Address				
6	City, State, Country				
7	Tel:		E-mail:		
8					
9	Mold Description				
10		Each	Qty	Total	
11	Vanity Top Molds with Built-In Bowls (Hat Molds Included)				
12	22" X 25" Newport Modular Mold - 111 Series	\$ 6,526.00	1	\$ 6,526.00	
13	22" X 31" Newport Modular Mold - 111 Series	\$ 8,436.00	1	\$ 8,436.00	
14	22" X 37" Newport Modular Mold - 111 Series	\$ 10,856.00	1	\$ 10,856.00	
15	22" X 43" Newport Modular Mold - 111 Series	\$ 11,264.00	1	\$ 11,264.00	
16					
17	Counter Top Molds with Built-In Backsplashes				
18	22" X 146" Adjustable All-Purpose Mold	\$ 9,642.00	1	\$ 9,642.00	
19	Dividers for 22" Countertop	\$ 202.00	8	\$ 1,616.00	
20	22 Inch Six Cavity End Splash Mold	\$ 4,396.00	1	\$ 4,396.00	
21				\$ -	
22	30" X 144" No Bowl	\$ 11,760.00	1	\$ 11,760.00	
23	Dividers for 25" Countertop	\$ 202.00	4	\$ 808.00	

\$ 2,000K - Cultured Marble Factory.xlsx

	A	B	C	D	E
1				1-Jan-24	
2					2
3	\$2,000,000 Cultured Marble Factory				
4	Name				
5	Address				
6	City, State, Country				
7	Tel:		E-mail:		
8					
9	Mold Description				
10		Each	Qty	Total	
11	Built-In Bowls (Hat Molds Included)				
12	Mold - 111 Series	\$ 7,831.20	2	\$ 15,662.40	
13	Mold - 111 Series	\$ 10,123.20	2	\$ 20,246.40	
14	Mold - 111 Series	\$ 13,027.20	2	\$ 26,054.40	
15	Mold - 111 Series	\$ 13,516.80	2	\$ 27,033.60	
16					
17	Built-In Backsplashes				
18	All-Purpose Mold	\$ 11,570.40	2	\$ 23,140.80	
19	Dividers	\$ 242.40	16	\$ 3,878.40	
20	Splash Mold	\$ 5,275.20	2	\$ 10,550.40	

Sign the Purchase Agreement and make a bank wire transfer.

Sunrise International Company
MOLDS, EQUIPMENT, SUPPLY & TRAINING AGREEMENT

Sunrise International Company

P. O. Box 877

San Jose, CA 95106 U.S.A.

Tel: (408) 230-3616

E-mail: sunrise@culturedmarblemolds.com

Name:

Address:

City, State, Country

Tel:

E-mail:

This \$ _____ agreement is entered into by and between Sunrise International Company, hereinafter referred to as "Seller" and _____, hereinafter referred to as "Buyer" for the purposes herein stated. The receipt is hereby acknowledged and the undersigned do hereby contract and agree as follows:

1. **AGREEMENT:** Seller hereby sells to Buyer all rights, title and interest in and unto Molds, Equipment, Supplies, Technical Knowledge and other goods itemized on separate document.
2. **TRAINING & FACTORY SETUP / EQUIPMENT INSTALLATION:** Sunrise International Company agrees to come to your factory and with the assistance of local labor and electrician, set up the equipment and commence training you and your staff. Training includes all Intellectual Know-How to manufacture cultured marble, onyx, granite, spray granite, metal flake and other formulas and techniques to produce bathtubs, showers, countertops, vanities, window sills, columns, soap dishes and other bath and kitchen building materials. Training also includes ongoing technical support free of charge. Buyer agrees to provide lodging during stay. Sunrise agrees to stay as long as customer requires, up to a maximum of 30

P. O. Box 877, San Jose, CA 95106, U.S.A.
Tel: (408) 230-3616 - Email: sunrise@culturedmarblemolds.com

days. A large factory set up takes approximately 7 days and the remainder of the time is dedicated to training new employees.)

3. Sunrise International agrees to provide on-going technical support to all clients who purchase a manufacturing package.
4. **TERMS:** Buyer agrees to pay unto Seller by bank wire transfer the sum of \$ _____. Payments shall not be considered paid until received by Seller. Bank wire transfer information will be provided upon consummation of purchase agreement. Contact us for details if Letter of Credit will be used for acceptable terms for Letter of Credit. If an LC is required add 3% of total cost of goods.
5. **FREIGHT:** Sunrise will make shipping arrangements to destination but Buyer has the option of making their own shipping arrangements. Freight must be paid prior to shipping.

Schedule A: Mold Package	
Schedule B: Equipment Package	
Schedule C: Supply Package	
Schedule D: Raw Material	
Schedule E: Installation Tools	
Schedule F: __ Weeks/Installation & Training \$6k/Wk	
Intellectual Know-How Included	
Ongoing Technical Support Included	
Total	

WITNESS our signatures this _____ day of _____, 2024

SELLER:

BUYER:

Sunrise International Company

By: _____

P. O. Box 877, San Jose, CA 95106, U.S.A.
Tel: (408) 230-3616 - Email: sunrise@culturedmarblemolds.com

After a factory is purchased

- We produce everything for the factory and ship it in ocean shipping containers.
- We come to your factory, set up the equipment and make everything operational.
- We will train you and your employees on all of the formulas and techniques
- We will give you all of the intellectual property and know-how.
- We will teach your team how to market the products.
- We provide follow up support for as long as you need it.

Here we are preparing your package for shipment:



Here is a factory ready to ship. Everything has been carefully crated and packaged for ocean shipping containers.



Molds are carefully loaded into the container



The container is then trucked to the port



The container is loaded onto the ship and on while it's making it's trek, you can start making final preparations to your building so it will be ready when we and your container(s) arrive.



A one-time purchase and these construction materials will never need to be imported again.

Jobs created for Benue people

Wealth created in Benue State

Imports reduced

Naira currency flight reduced

After your containers arrive we will come to set up your factory.

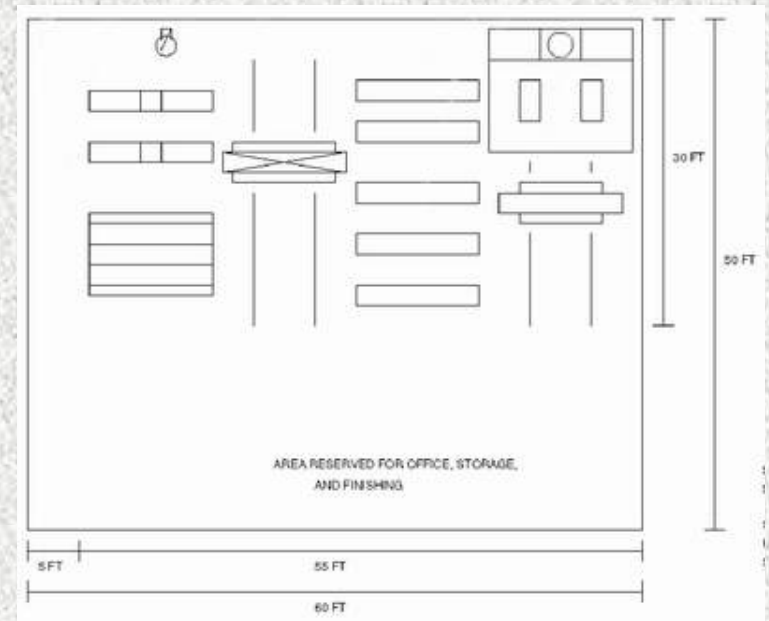
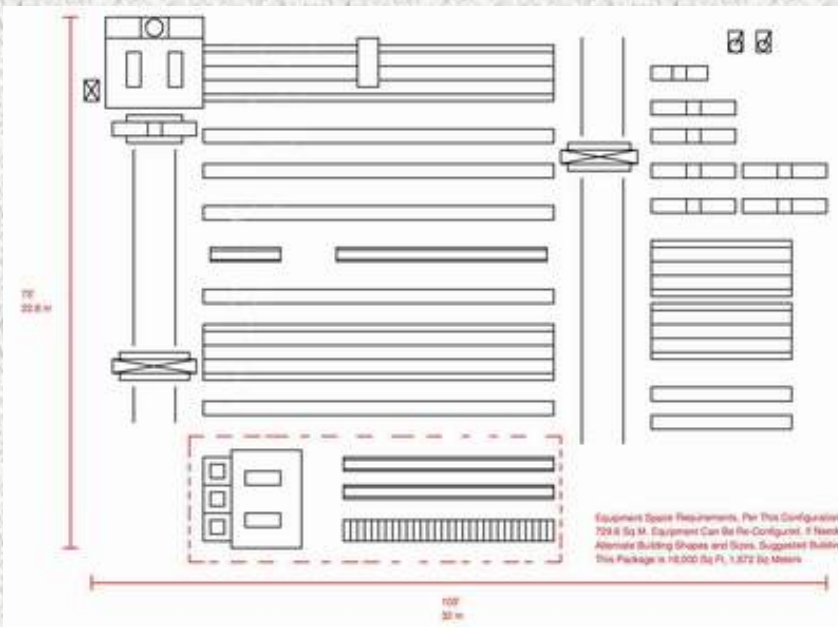

Here's a brief glimpse of setting up a factory.





Complete... Ready for production.



Hands on - Factory Training

Training

We don't simply sell you molds and equipment and send you on your way. After your factory arrives in the shipping containers we will come to your factory and with the help of your staff, set it up and begin training. We train all of our customers who purchase a mold and equipment package from us to manufacture the most exquisite products in the world. Training is crucial and it is one of the most important things we do. We have been setting up factories and training and supporting our new customers since 1990 and we will continue to support all of our customers as we can only be successful if you are successful.

You won't need to waste money on R & D and costly trial-and-error methods. The technology and know-how will be handed to you during training and in a written training manual that is filled with over 30 years of experience. We will teach you and your staff how to:

1. Work with Colors
 2. Cultured Marble
 3. Cultured Onyx
 4. Cultured Granite
 5. Spray Granite
 6. Metal Flake / Sparkle
 7. Inlays
 8. Tortoise Shell Veining
 9. Flexible Marble
 10. Textured Flooring
 11. Two Tone Effects
 12. Lightweight Marble
 13. Solid Colors
 14. Multiple Edge Styles
- ... and much-much more.



Our comprehensive training program guarantees you will learn how to manufacture exquisite products from Day-One.

Not only is training the most important thing we do but for us it's the most exciting. It is when we get to spend time in the factory teaching new eager employees how to manufacture something they've never seen before and often, it's their very first job. We never get tired of their Oohhs & Aahhs every time something is popped off the mold. So, be prepared for some rewarding and very exciting days during training.



Working with Colors:

You will soon learn how important colors are to your customers. In fact, having the ability to offer your market any color 'under the sun' will be what brings you many customers, especially in the custom and retail market. Your customers have been limited to the same boring, sterile white bathroom fixtures for far too long and they're going to be delighted to have a source for their creativity.



Cultured Marble Formula

Of all the formulas, cultured marble is the most common product that most factories produce. Your veining can be as bold or as subtle as you like. This will also be the formula you'd use if you make solid color products. As you progress, your staff will want to experiment with veining techniques and even come up with new ones of their own.



This
<---

Made
This
->



Cultured Onyx

Cultured Onyx is a very elegant product that no picture can really capture. Just Like with natural onyx, it is semi-transparent, allowing you to see 'into' the product. You're not only seeing what is on the surface like you do with most other formulas.



Here are a couple of photos showing the beauty of Onyx



Cultured Granite

As with marble and onyx, you can make so many variations of granite. You can make big particle, small particle and a wide variety of colors.

Big Particle

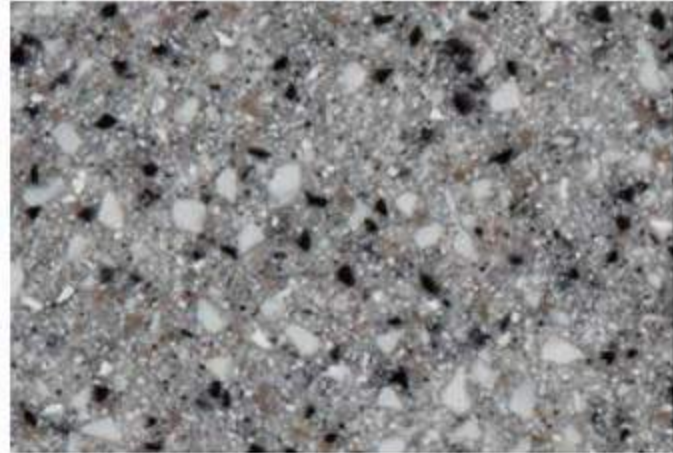
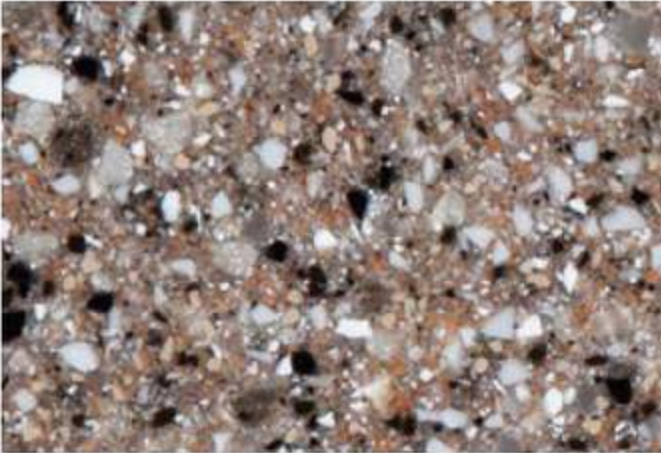

Small Particle

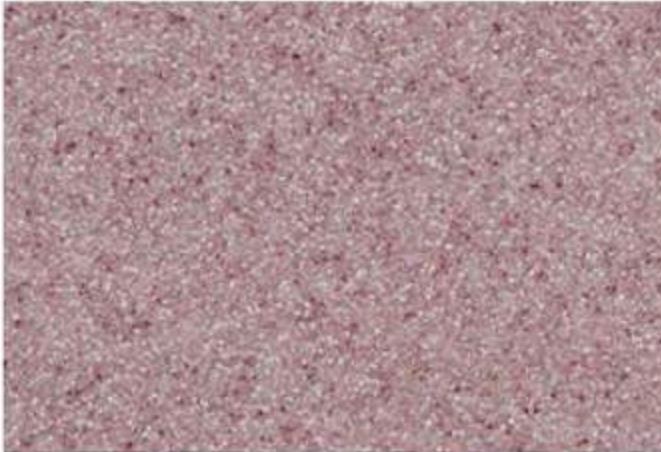

Cultured granite is popular everywhere. Most fast-food restaurants use it throughout their restaurants.



Not only are Boeing and Airbus using cultured granite sinks but did you know that many of the same materials you will be using are used to make these big birds?



Here is a cultured granite shower pan and you saw some granite wall panels earlier in this presentation. Whatever mold you're using, it can also be used to make granite.



Spray Granite

Spray granite creates the same beautiful granite but for less material cost. You will have a thin 2 mm coating of granite and back fill it with your cultured Marble matrix.



Sparkle / Metal Flake / Metallic

Trends come and go and this is one that left us a few years ago but is back like a vengeance. It's being used in home installations in a more subtle way but you can get bold and wild in bars and restaurants. This makes a very 'custom' product and one never seen in Nigeria before.

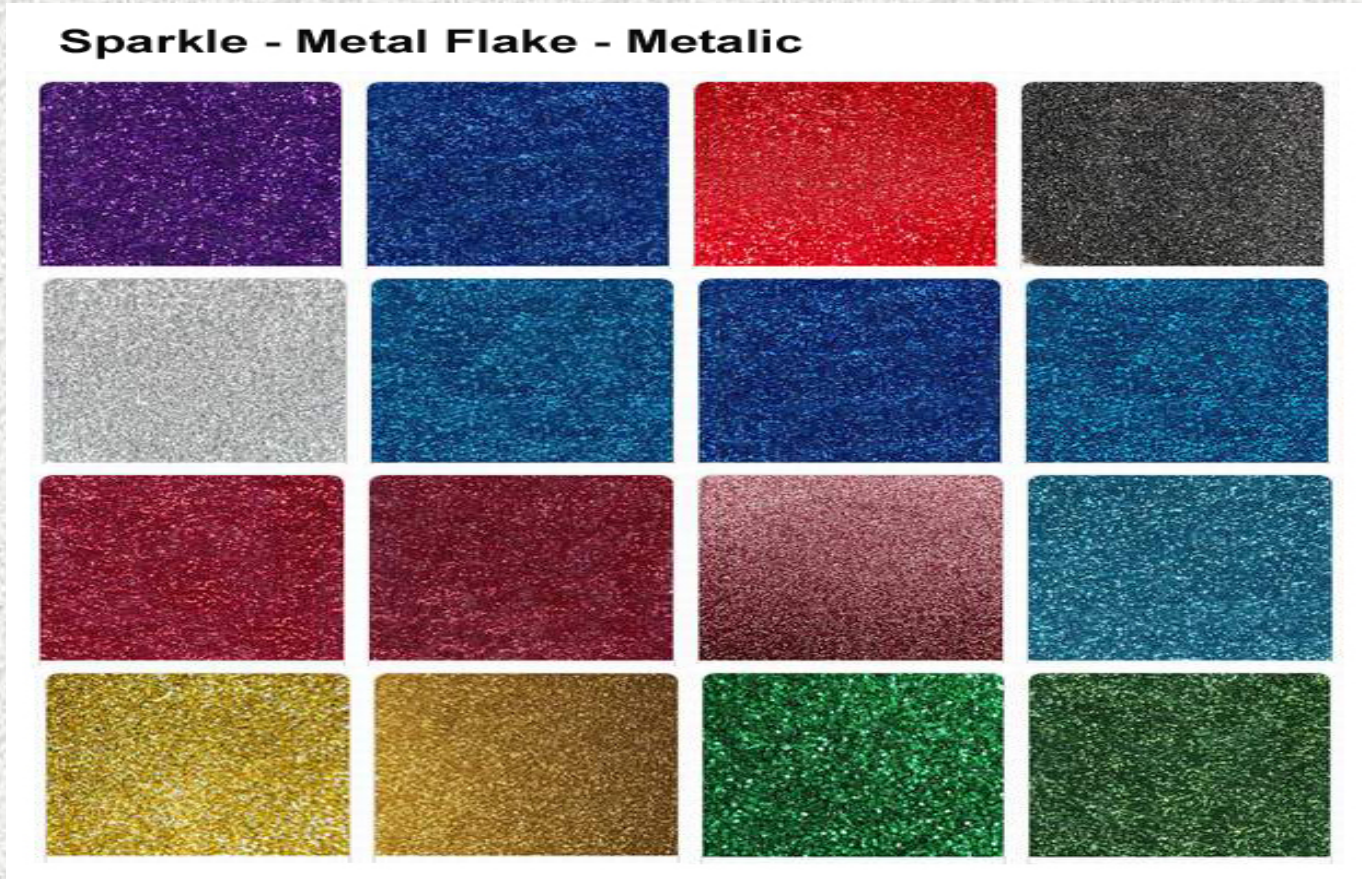

Inlays

We embedded a picture in between the clear gel coat and marble. It makes a very Stunning effect.



Tortoise Shell

This is a decorative veining technique you can produce using marble, granite, onyx or flexible marble, and we have to add, in ANY color

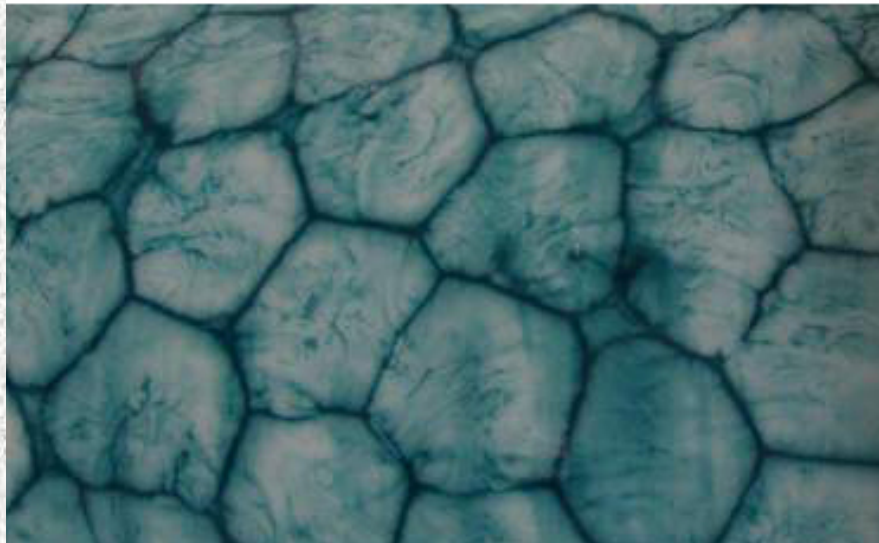

Flexible marble/onyx/granite

You can bend your marble before it is fully cured, then let it set to cure in the shape you desire.



Textured Flooring

You can make textured flooring or wall paneling, with a tile pattern or without. What your customers will like about your textured pieces is that, just like your vanity tops, Showers and other products, it is seamless; no place where dirt can hide.



Textured marble with a tile appearance but with the same seamless benefit.



Two-Tone Effects

You can make two-tone sinks with one or multiple bowls, and it will be all one piece. No seams or grout lines. The counter top, bowl, and backsplash are all one piece.



We often take a photo of the trainees 'First Sink', during training class. Kamal from Kazakhstan wanted to start with something unique for his "First Sink" so we made a two-tone onyx and granite sink. When you make an onyx sink, you can put a light under the cabinet and the light will shine through, making a nice night light.



Light Weight Marble

This 60" X 60" (152 cm X 152 cm) corner bathtub is fresh off the mold in a training class. It weighs 100 KG. If you have a large product like this that you need to carry upstairs, you can consider making it lighter.



Solid Colors

Not everybody wants veined cultured 'marble'. You can make solid colors too, whether it's soft neutral colors or bold colors. We'll show you two methods to achieve this.



Edge Styles

You will be trained how to make the various edge styles that we referred to earlier including simple Flat, Ogee, Double Ogee, Bullnose, Texas Ogee, Chamfer Edge, Dripless and deep drop edge styles.. With only a little extra effort and tiny bit of material (cost) you can offer your customer up 8 edge styles.



We all worked hard and played hard. This group has just been fully trained and are ready to manufacture. The following pages show more photos taken during some of our training classes.



Every formula is written on a board so you can take notes, video, or photos. If you will be using metric in your factory, we will conduct your training class using metric.

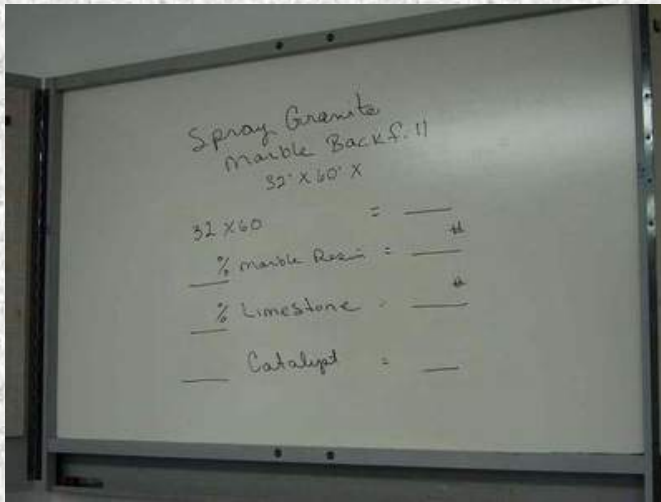

Proudly showing off 1st piece



Learning Mixing & Veining Techniques



Learning Detailing Procedures



It's all in the details



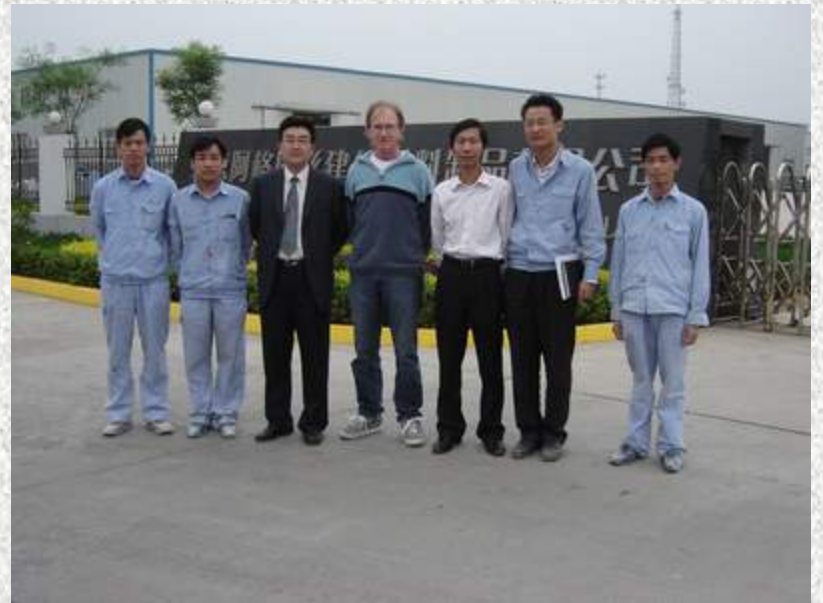



Get started. Grow wealth and manufacture locally.

You will make:

Sinks
Bathtubs
Shower Pans
Wall Paneling
Shower Surrounds
Countertops
Grecian Columns
Soap/Shampoo Holders
Trim Molding
Window Sills
Table Tops
Mirror Frames
Any Flat Slab Applications
Misc Bathroom Accessories

For:

Homes
Hotels
Schools
Student Housing
Restaurants
Fast Food Chains
Retail Shops
Bars
Coffee Shops
Banks
Hospitals
Clinics
Fitness Centers
Your market is unending.

We'll also teach you how to market your products and bid a job for both large housing projects and small custom jobs.



...or whether you'll produce one-of-a-kind masterpieces, or...



....or see an opportunity for a custom installation in a high end estate...



We'll show you how to bid it, sell it, and make it.

The logo features the text "Sunrise International Company" in a white serif font, centered within a black rectangular background. A bright yellow sunburst with radiating lines is positioned behind the word "Sunrise".

Sunrise International Company

Call us now to get started

Tel: +1 408 230 - 3616

E-mail: sunrise@culturedmarblemolds.com

Website: www.culturedmarblemolds.com

Viber & Whatsapp on telephone number above.